

# COGEN SYSTEMS DUAL FUEL SYS.

RUN YOUR DIESEL GENSET ON GAS  
SAVE 50% DIESEL FUEL COST- CUTTING

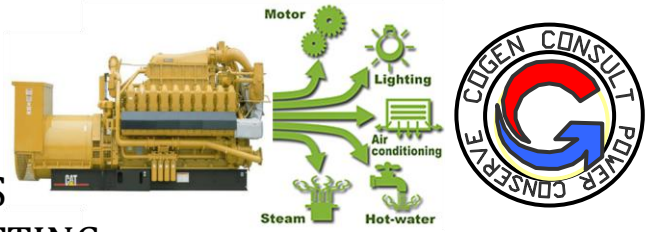

**Operate your Diesel Genset Gas,LPG,BIOGAS,COALGAS & Save 50%**

**40% Diesel & 60% Gas ( LPG) saves 50% Diesel Fuels Cost . Use Your Boiler Gas /LPG Cylinder Gas,and Save Millions of Pak Rs. Profit from Knowledge- New & Safe Technology from USA/Europe.**

**1KWeh (unit) Cost with Diesel Fuel= 22 Rs.  
1KWeh (Unit) Cost Diesel Mix Gas = 11 Rs.**

- No Changed on Original Engine
- No Changed on Genset safeties
- Proven American/Europe Technology .
- Investment Payback within 1 Month.
- No Start Stop Problem.
- Fully Automatic Control & Safeties.
- Gas & Diesel Flow Metering
- Engine Exhaust temp. Monitoring.

GEN -12 HR/DAY	DIESEL	Rs/Month
100 KWE DG	@ 28 LITR/HR	Rs -2100/Hr
DIESEL 100% @75 Rs/Ltr	360 H /Month LDO/12 HR/DAY	7,56,000
DUAL FUEL 40% LDO /PM	360 Hrs/Month	3,02,400
60% GAS @ 0.3 100% M3/KWeh	225 Rs/Hr @ 0.18 m3/EKWH @ 60%	81,000
Total Fuel LDO+GAS	302400+81000=	3,83,400
Monthly Saving 50%	3,83,400/7,56,000	50% SAVING
Dual Fuel COST 100 KWE Rs.	2,50,000 /-	500,000/-
Invest Payback	350,000/7,45,200	1 MONTH

SO WHY NOT WASVE 50% DIESEL COSTS OR

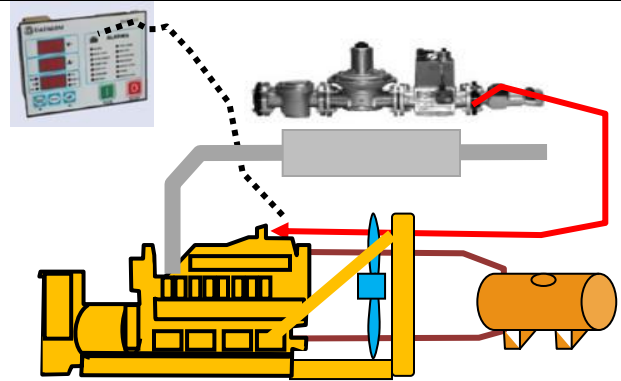

- KWe Energy based gas Fuel regulation for accurate fuel Economy
- Alarms Protections Indication, Voltage, Cuurent Indiacator, Lube Oil, Over Current,Under Frequency ,Over Speed, Jacket water Temp. Hi, safeties
- Call for Free Energy Audit Survey.
- Use Engines Exhaust Smoke for Air Conditioning Multi Energy Absorption Chiller
- Call for survey and audit

- **Engr. Khalid Saeed 0300 8287009**  
- **111-A/2,3<sup>rd</sup>. Street,Ph-6, Kh-e-Muhafiz,DHA,Karachi-75500,Emial:**  
[cogenpak@gmail.com](mailto:cogenpak@gmail.com),  
Web:[www.cogensys.pk](http://www.cogensys.pk)

# COGEN SYSTEMS

## DUAL FUEL SYS.

RUN YOUR DIESEL GENSET ON GAS  
SAVE 50% DIESEL FUEL COST- CUTTING

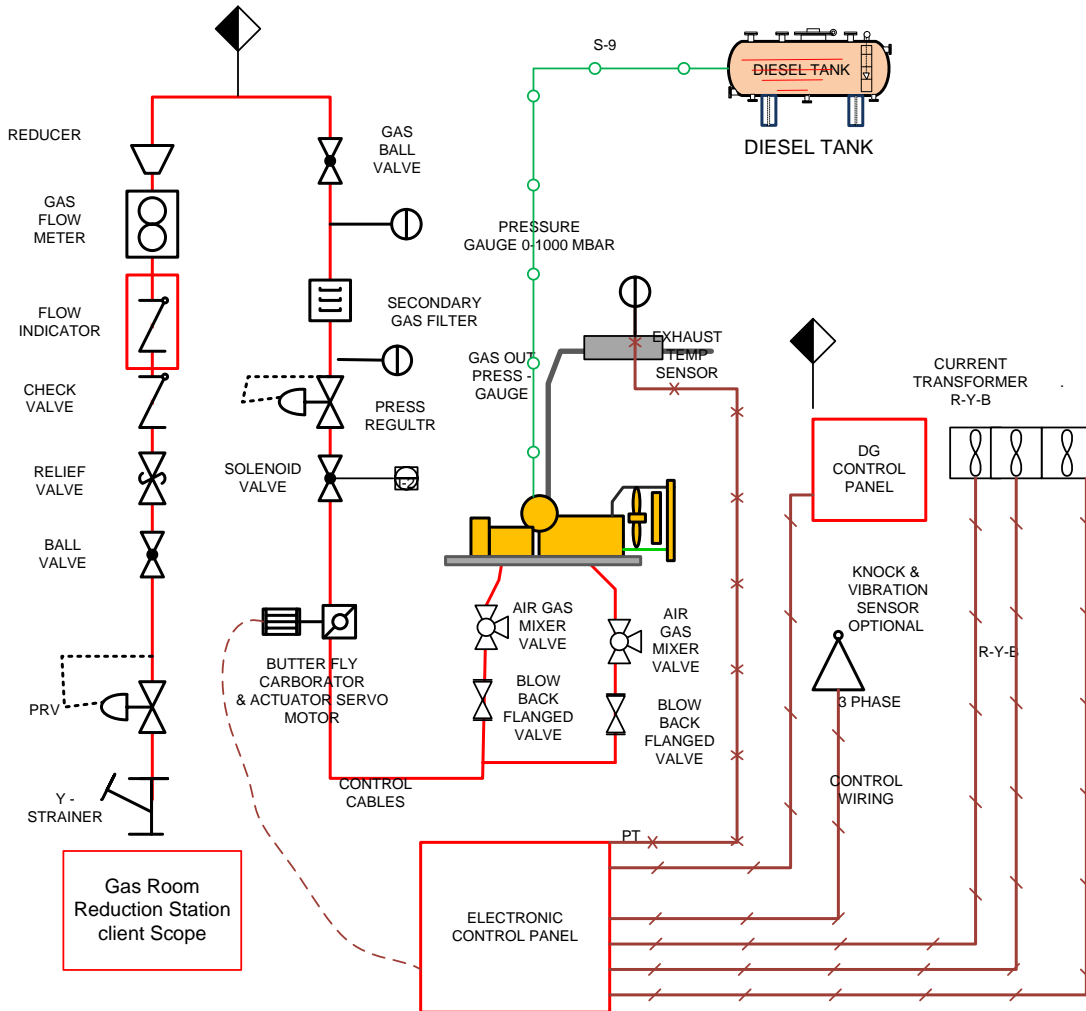
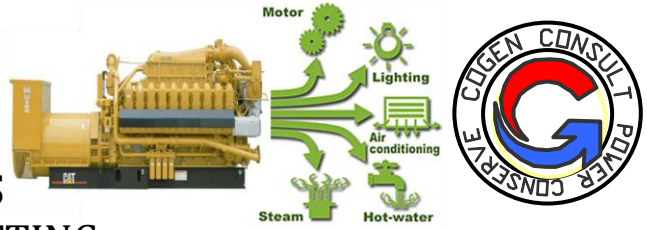

### COGEN - DUAL FUEL SYSTEM

MIXE GAS WITH DIESEL FUEL DURING OPERATION 40:60% AND REDUCE UNIT COST 50% (FROM Rs.25 TO 13 /HR/EKWH) , NOT CHANGES ON ORIGINAL GENSET,EXTERNAL ADDITION OF GAS FUEL REGULATIONS,CONTROLLERS,CARBORATOR,AUTOAMTION,SAFETIES,PRPROTECTIONS ,MONITORING,ALARMS.HOOTER,DATA LOGGING,OPERATORS TRAINING,FUEL ECONOMY,MEASURMENT ,GUARANTEES,WARRANTIES,BACKUP SUPPORT ,PERIODIC VISITS,CARETAKING RETAINING CONTRACT.